

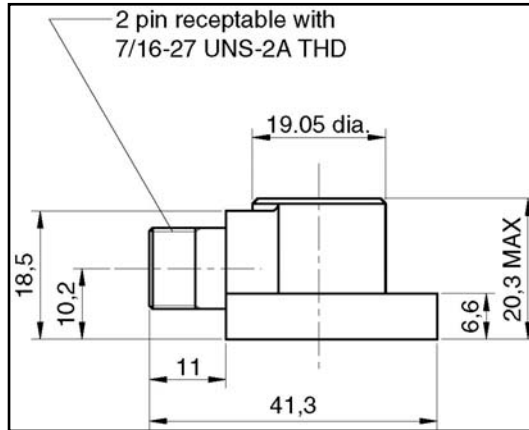

# Accelerometer type 8315 data sheet

## 1. Application



Charge type accelerometer.

## 2. Usage

The 8315 Accelerometer is designed for permanent vibration monitoring installations in a wide variety of applications. It is intended as a general-purpose monitoring transducer. It may be used in areas where there is radiation.

The accelerometer utilises a "shear" construction that significantly reduces transient temperature and base strain outputs, while maintaining a high resonance when mounted and a high operating temperature.

## 3. Technical Data

### Dynamic:

Sensitivity (Axial): ..... 10 pC/ms<sup>-2</sup>, ±5%  
Measuring range (peak): ..... ±20,000 ms<sup>-2</sup>  
Resonant frequency, typical: ..... 28 kHz  
Frequency response: ..... ±10%: 1 Hz to 10 kHz

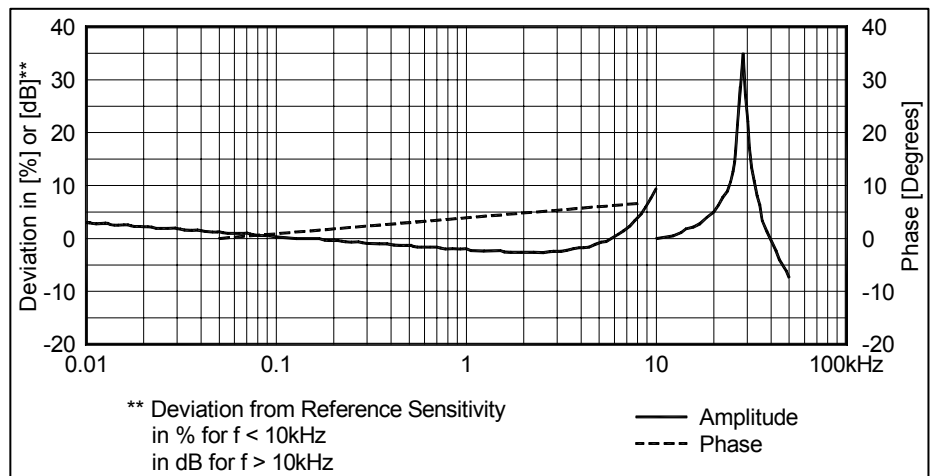

Transverse response:  
Resonance frequency, typical: ..... 9.4 kHz

Maximum sensitivity:..... <4%  
 Amplitude linearity:..... >1% increase per 2,000 ms<sup>-2</sup>  
 Temperature response, typical:..... ±10% from -53°C to +125°C

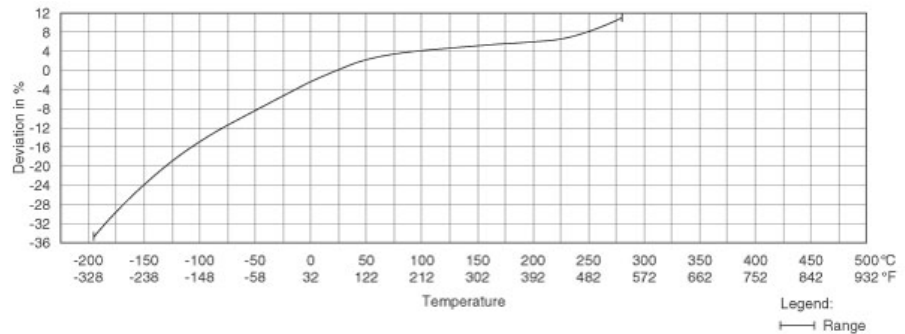

Typical temperature response

**Electrical:**

Resistance, typical  
 Between signal pins (+25°C): ..... >10 GΩ  
 Between signal pins (max temp.):..... >50 MΩ  
 Each signal pin to case (+25°C): ..... >10 GΩ  
 Each signal pin to case (max temp.): ..... >50 MΩ  
 Capacitance, typical  
 Between signal pins, excl cable: ..... 12,2 nF  
 Either signal lead to case: ..... <30 pF  
 Unbalance between pins:..... <2 pF  
 Base strain sensitivity, typical in base plain at 250µε: ..... 0.008 ms<sup>-2</sup>/µε  
 Temperature transient sensitivity, typical:  
 with 3 Hz high pass filter: ..... 0.05 ms<sup>-2</sup>/°C  
 Isolation (500 VDC at -50°C to 125°C): ..... >100 MΩ  
 Grounding: ..... Signal wires isolated from case

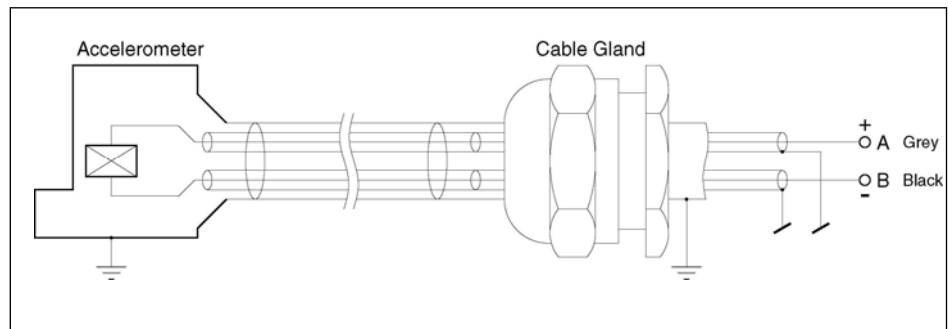

Electrical layout

**Environmental:**

Maximum acceleration limits (peak)  
 Shock limit: ..... 10,000 ms<sup>-2</sup>  
 Sinusoidal vibration limit: ..... 5,000 ms<sup>-2</sup>  
 Temperature range (accelerometer only):..... -196°C to +260°C  
 Electromagnetic sensitivity, 50 Hz, 38 mT: typical: ..... 25 ms<sup>-2</sup>/T  
 Enclosure protection with cable integrated: ..... IP 67  
 Accelerometer hermetically sealed.

**Physical:**

Weight (cable not included):.....62 g

Case material: ..... Stainless steel, 316L  
 Polarity:.....Positive on left pin or gray signal wire  
 Acceleration directed from base into body  
 Piezoelectric element construction:.....Shear, Piezite P-8®  
 Footprint: ..... ARINC  
 Mounting:.....3 x M4  
 Torque: ..... 2.9 Nm

ARINC Footprint:

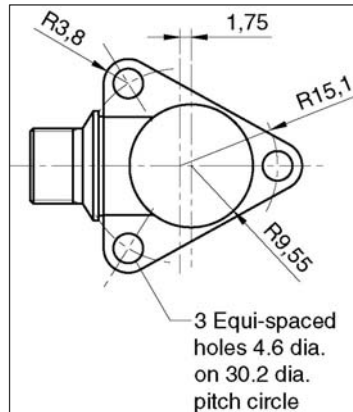

**Mounting space:**

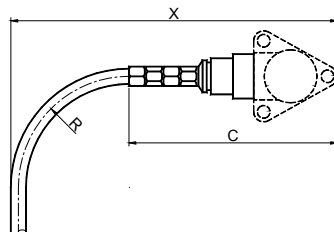

Minimum bending radius ( R ): 39 mm  
 Accelerometer height w. integrated cable(C): 70 mm  
 The mounting space can be calculated as  $X_{min} = C + R$

The figure shows the dimension for the Type 8315 with connected cable.

**Connection to charge preamplifier:**

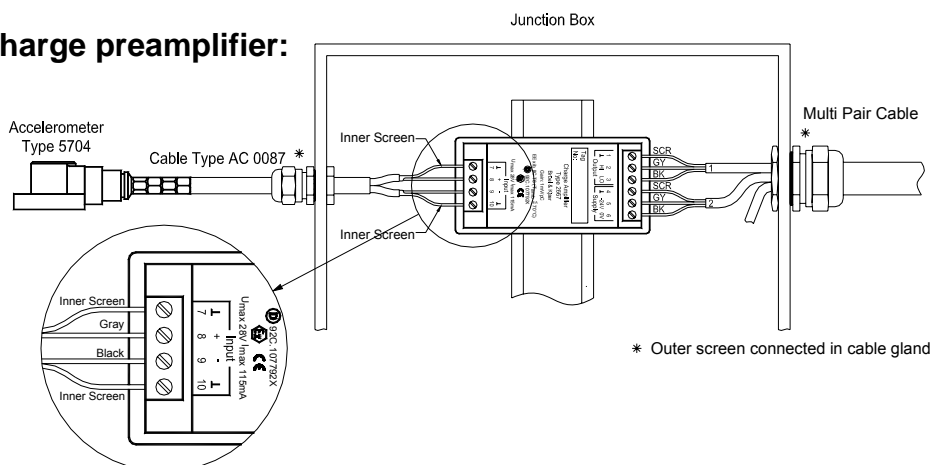

Brüel & Kjær Vibro A/S reserves the right to change specifications without notice

**B & K s.r.o.**  
 Palisády 20, 811 06 Bratislava  
 02/ 544 307 01  
 bk@bruel.sk, www.bruel.sk